

R100-R60

Gantrail Re-levelling & Re-alignment System

A world of crane
rail expertise.

www.gantrail.com



UK Patent Application number GB1513369.7

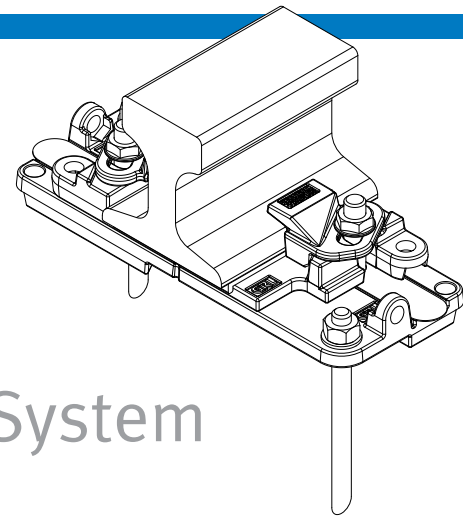

R100-R60

Gantrail

Re-levelling & Re-alignment System

The Gantrail fully adjustable re-levelling and re-alignment crane rail system has been designed for all situations where post-installation vertical and horizontal settlements/movements of the foundation are expected in both the short and long term.

With the ever increasing demands for space to build new or expand container port backup yards, reclaiming land has become commonplace but with this comes many challenges for the designers, not least is the issue of foundation settlement and how to deal with it.

With many construction projects now taking the form of Engineering, Procurement, and Construction (EPC) or Design and Build, it is the Contractor's responsibility to develop the most cost effective solution that meets the client's performance specification.

To design a foundation that will not move is unrealistic and ultimately not cost effective. The Gantrail re-levelling and re-alignment system offers designers an economical solution that allows significant cost reductions in foundation design by allowing reasonable amounts of settlement to occur post installation.

If the crane rail system begins to move outside of operational tolerances, it can be re-levelled or re-aligned with minimal downtime.

This makes concrete beam type construction a more viable option and serious alternative to traditional concrete sleeper and ballast systems that require regular annual maintenance and associated downtime.

COMPONENTS:

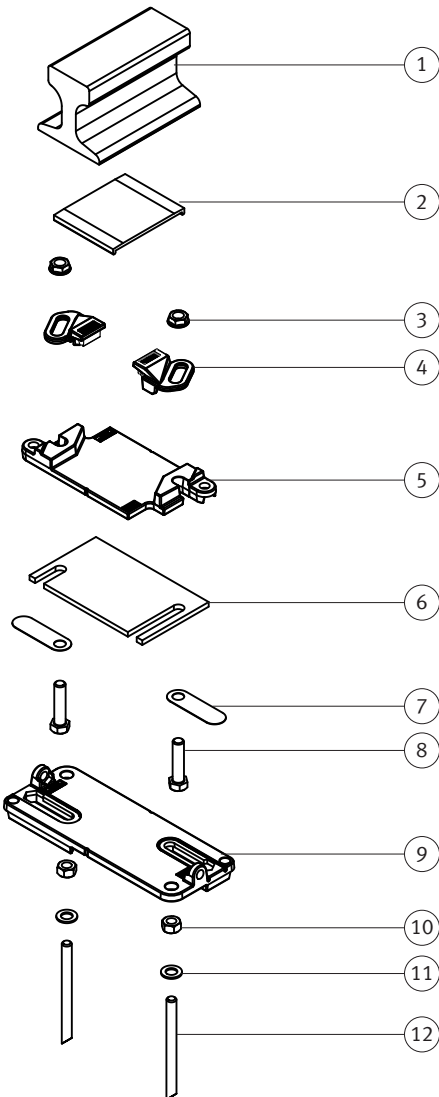

- | | |
|--|---|
| 1. Rail | 7. Slot cover |
| 2. Gantrail MK2 Pad | 8. Assembly bolt |
| 3. Locking Nut and washer combination | 9. Gantrail bottom plate (R100/R60/***/B) |
| 4. Gantrail clip cap | 10. Nut |
| 5. Gantrail top plate (R100/R60/***/T) | 11. Washer |
| 6. Shim plate(s) | 12. Holding down bolt |

SPECIFICATIONS:

RECOMMENDED MAX VERTICAL LOAD;
 R100-R60-165 = 350 kN
 R100-R60-220 = 500 kN
 RECOMMENDED MAX HORIZONTAL LOAD = 120kN

ADJUSTMENT:

100mm VERTICAL RAIL ADJUSTMENT
 60mm HORIZONTAL RAIL ADJUSTMENT

DIMENSIONS (mm):

REF NO.	LENGTH	WIDTH	HEIGHT	WEIGHT kg
R100/R60/165/T	280	165	15	16.3
R100/R60/165/B	420	165	30	
R100/R60/220/T	280	220	15	20.9
R100/R60/220/B	420	220	30	

FEATURES:

- 100mm vertical adjustment via introduction of shim plates
- 60mm horizontal adjustment via slotted holes
- Interchangeable hex head bolts to allow for variations in vertical settlements
- Integral re-levelling and re-alignment system for ease of adjustment
- Alignment markings to aid installation.

The R100-R60 system comprises;

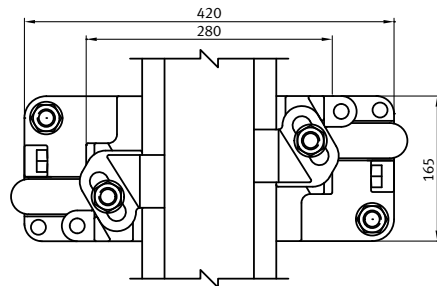

R100-R60-165 PLAN

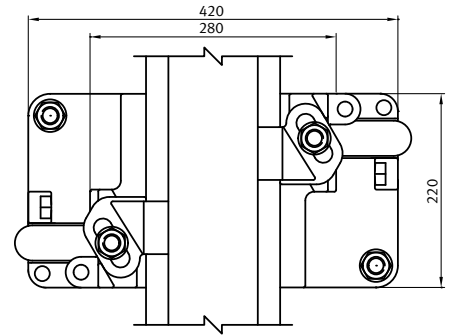

R100-R60-220 PLAN

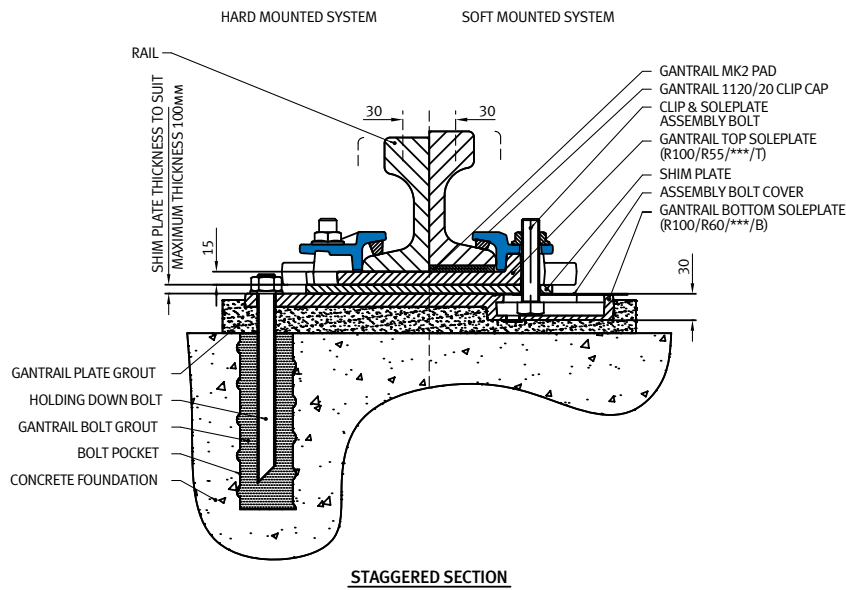

STAGGERED SECTION

APPLICATIONS:

- Container port backup yards – ASC/RMG systems
- Stacker/Reclaimer systems
- Automated Warehouses

Design Characteristics

The Gantrail fully adjustable re-levelling and re-alignment crane rail system comprises individual rail support assemblies that are generally at even spacings along the rail. These can be anywhere from 500 to 900mm providing rail stress and deflection remain within acceptable limits.

Each individual assembly consists of two plates that are fixed together with two standard hexagon head assembly bolts. The bolts also act to fix the Gantrail rail clips which allows the use of their proven 'double wedge' design to provide additional locking of the plates when lateral loads are applied. The integral self-tightening Gantrail rail clips rigidly fix the rail from lateral movement whilst allowing longitudinal movement resulting from thermal variations. At the initial installation, the assembly bolts are provided in a suitable length to allow an initial amount of vertical adjustment whilst providing adequate clearance to crane guide wheels and bogeys. Between the top plate and underside of the rail is Gantrail Mark 2 pad that ensures an even distribution and transmission of vertical loads into the plates and ultimately the concrete foundation. The bottom plate is fixed to the concrete foundation by two holding down bolts. Once the precise final level of the rail is achieved, a layer of non-shrink epoxy grout is placed between the bottom plate and concrete foundation.

Regular surveys at specified intervals will determine whether the crane rail system is moving outside of operational tolerances. This will identify any areas of the rail that need vertical or horizontal adjustment.

To adjust the system vertically, the nuts securing the assembly bolts are loosened or removed. Nuts are inserted into the special apertures in the top plate to create a unique levelling facility. Screws are inserted and rotated to accurately raise the level of the top plate and rail to the precise level required. Shim plates are then inserted between the top and bottom plates. If sufficient vertical adjustment cannot be achieved with the original assembly bolts these can be interchanged easily with longer bolts.

To adjust the system horizontally, this can initially be achieved with 20mm of adjustment from the Gantrail rail clips without the need to adjust the complete plate assembly. However, if this is not sufficient, the nuts securing the assembly bolts are loosened and the top plate repositioned via the 40mm slotted holes in the bottom plate. Precise repositioning is made easy by inserting nuts into the special apertures in the bottom plate to create a unique alignment facility. Screws are inserted and rotated to reposition the top plate and rail laterally to the precise alignment required.

Once all adjustments have been made, all nuts are re-tightened to the specified torque.

R100-R60

Gantrail Re-levelling & Re-alignment System

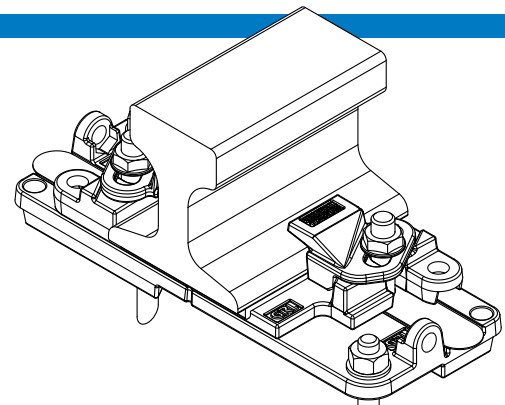

	F mm	C mm	A mm	1. CLIP CAP REFERENCE WITH PAD	2. CLIP CAP REFERENCE WITHOUT PAD
MRS 85	152.4	102.9	152.4	1120/21/45	1120/21/38
AS 86	150	101.6	152.46	1120/21/45	1120/21/38
MRS 87 A	152.4	101.6	152.4	1120/21/45	1120/21/38
MRS 87 B	152.4	102.2	152.4	1120/21/38	1120/21/38
QU 100	150	100	150	1120/21/38	1120/21/38
ISCR 100	150	100	150	1120/21/38	1120/21/38
UIC 60	150	72	172	1120/21/38	1120/21/38
SP 100	150	108	150	1120/21/38	1120/21/38
171 CR	152.4	102.9	152.4	1120/21/45	1120/21/38
175 CR	152.4	102.2	152.4	1120/21/38	1120/21/38
131 AREA	152.4	74.2	180	1120/21/38	1120/21/38
132 AREA	152.4	74.6	181	1120/21/38	1120/21/38
66 kg	152.4	75.1	181	1120/21/38	1120/21/38
68 kg	152.4	73.4	185.7	1120/21/38	1120/21/38
KP 100	150	100	150	1120/21/38	1120/21/38

THIS SYSTEM IS DESIGNED FOR RAILS WITH AN APPROXIMATE FOOT WIDTH (F) OF 150MM, BUT CAN BE USED FOR A WIDER SELECTION OF RAILS THAN ILLUSTRATED. THIS MAY RESULT IN A LOSS OF ADJUSTMENT FROM THE CLIPS. PLEASE CONTACT GANTRAIL TO DISCUSS OTHER POSSIBLE RAILS. GANTRAIL may change or improve their products and also alter specifications without notice.

INSTALLATION INSTRUCTIONS:

HOLD DOWN BOLT TIGHTENING TORQUE to suit project requirements
(typically 120Nm)

ASSEMBLY BOLT TIGHTENING TORQUE 475Nm (impact wrenches can be used)

Please contact GANTRAIL, for full installation instructions.

A world of crane rail expertise.

www.gantrail.com



Gantry Railing Ltd
Sudmeadow Road
Hempsted
Gloucester GL2 5HG
ENGLAND

Tel: +44 (0) 1452 300688
Fax: +44 (0) 1452 300198
E-mail: info@gantrail.com

Gantrail (Middle East) Ltd
P O Box 61428
Jebel Ali Free Zone
Dubai
United Arab Emirates

Tel: +971 4 8812 935
Fax: +971 4 8812 936
E-mail: gme@gantrail.com



Certificate No. 5180

R100-R60/ET/07/15